

NOTES:

- (1) INLET/OUTLET, ARE AVAILABLE IN IMPERIAL, METRIC OD/ID, NPT PIPE AND ANSI FLANGES.
- (2) FINISH: UNPAINTED 409SS

REVISIONS				
ZONE	REV.	DESCRIPTION	DATE	APPROVED

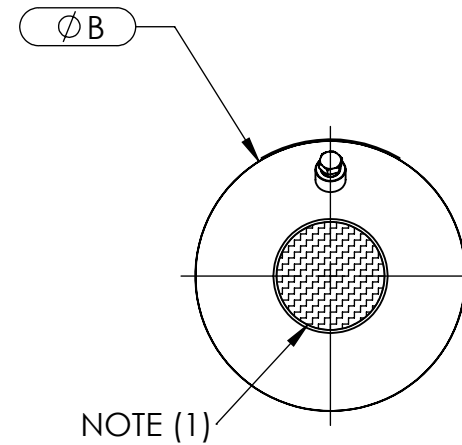
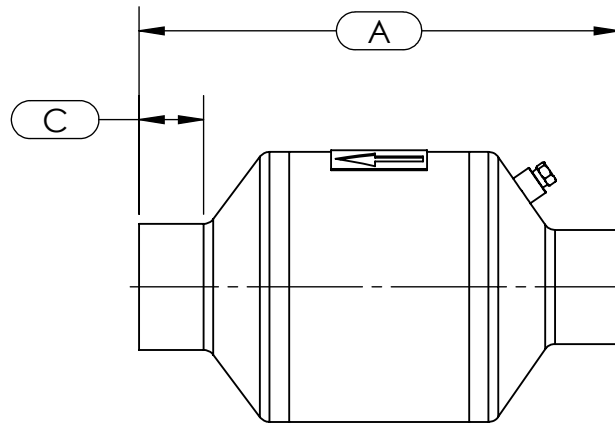

MODEL	HP RANGE	DIMENSIONS		
		A	ϕ B	C
3SXT-P	1-14 HP	7.50	2.63	.75
4SXT-P	15-30 HP	9.00	3.63	1.0
5SXT-P	31-56 HP	9.50	4.63	1.25
6SXT-P	57-90 HP	10.50	5.63	1.25
7SXT-P	91-130 HP	11.00	6.63	1.25
8SXT-P	131-190 HP	12.50	7.63	1.25

CATALYTIC EXHAUST PRODUCTS LIMITED

30 INTERMODEL DR. # 19-22, BRAMPTON, ON
 TEL: (905)-799-9770 FAX: (905)-799-9771

TOLERANCES ARE AS FOLLOWS
 UNLESS NOTED OTHERWISE
 1 DEC PLACE \pm .015
 2 DEC PLACES \pm .010
 3 DEC PLACES \pm .005

MODEL 3SXT-P TO 8SXT-P
 DIMENSIONAL DETAIL

DRAWN BY: Jose C.	B	DWG. NO. 3SXT-P_8SXT-P	REV
ISSUED: 23/04/2008	SCALE: N/A	WEIGHT:	SHEET 1 OF 1