

**NOTES:**

- (1) APPROXIMATE MAXIMUM HP LIMITS. PLEASE CALL THE SALES OFFICE FOR FURTHER INFORMATION
- (2) FINISH:FLAT BLACK HIGH HEAT PAINT

REVISIONS				
ZONE	REV.	DESCRIPTION	DATE	APPROVED

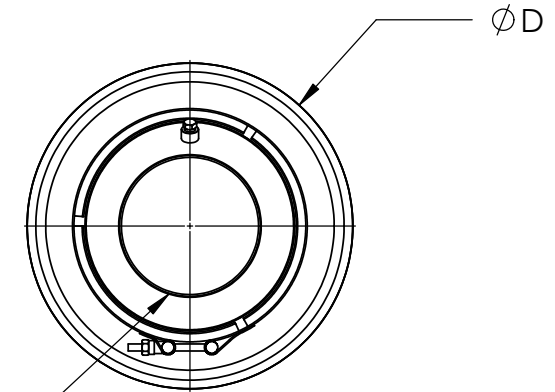
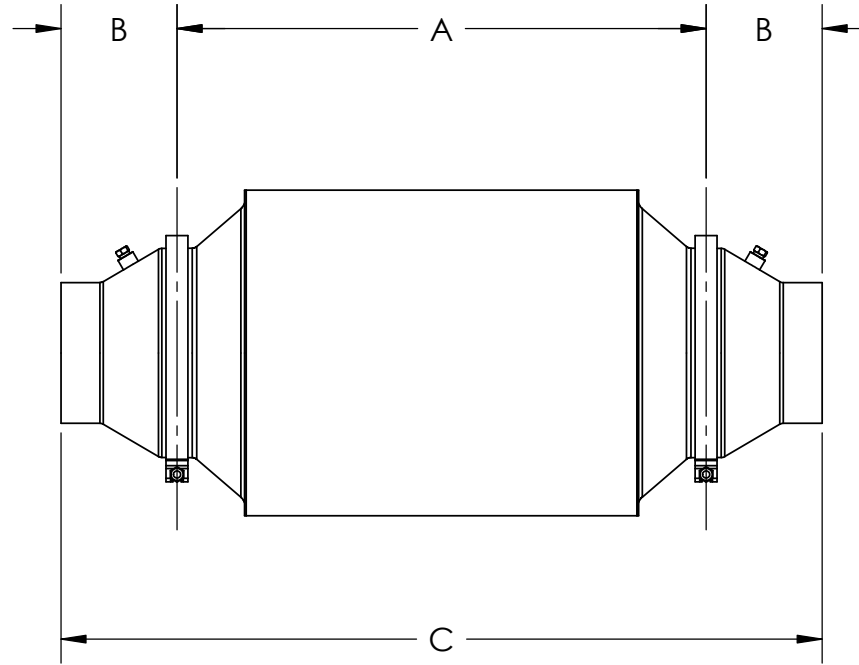

INLET AND OUTLET DIAM ARE AVAILABLE IN 2.0",2.25",2.5",2.75",3.0",3.5" AND 4.0" ID. OTHER SIZES IN IMPERIAL,METRIC,NPT PIPE AND ANSI FLANGES ARE AVAILABLE UPON REQUEST.

MODEL	A	B	C	D	MAX HORSEPOWER
912SXS	16.50"	4.13"	24.75"	9.75"	150 HP
1050SXS	16.50"	4.13"	24.75"	10.75"	200 HP
1212SXS	17.50"	4.13"	25.75"	12.00"	225 HP
1214SXS	19.50"	4.13"	27.75"	12.00"	250 HP
1215SXS	20.50"	4.13"	28.75"	12.00"	300 HP
1515SXS	26.75"	4.13"	35.00"	15.75"	400 HP
2015SXS	32.00"	4.13"	40.25"	20.75"	600 HP

**CATALYTIC EXHAUST PRODUCTS LIMITED**

30 INTERMODEL DR. # 19-22, BRAMPTON, ON  
TEL:(905)-799-9770 FAX:(905)-799-9771

TOLERANCES ARE AS FOLLOWS UNLESS NOTED OTHERWISE  
1 DEC PLACE ±.015  
2 DEC PLACES ±.010  
3 DEC PLACES ±.005

921SXS TO 2015 SXS,ASSEMBLY

DRAWN BY:  
Mike.B

**B** DWG. NO. 912SXS-2015SXS

REV

ISSUED:6/26/06

SCALE:N/A

WEIGHT:

SHEET 1 OF 2