

REVISIONS				
ZONE	REV.	DESCRIPTION	DATE	APPROVED

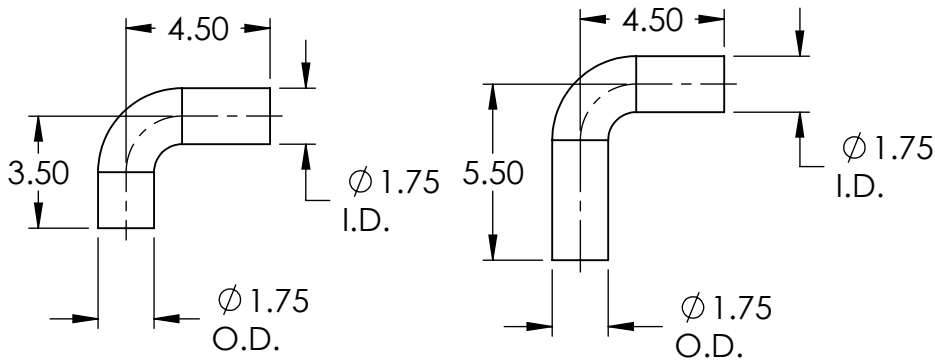

1 3/4 U-BOLT CLAMP

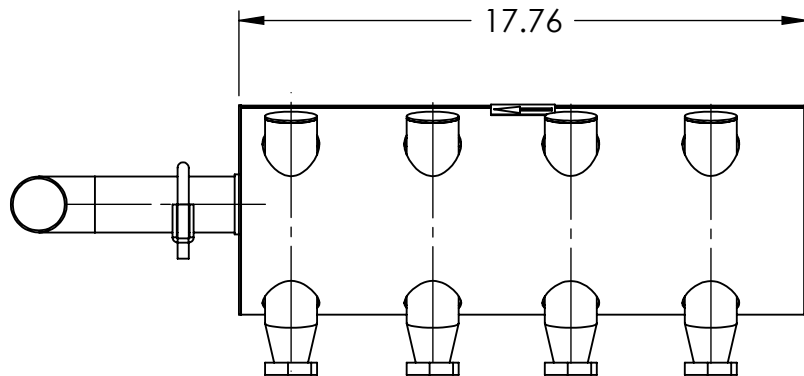
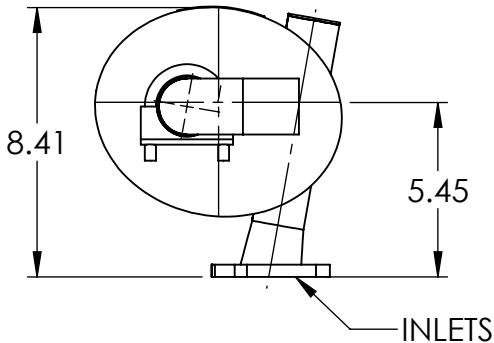
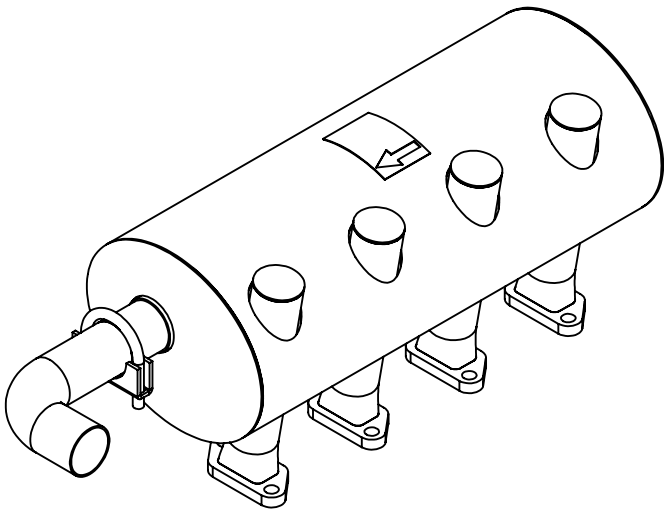
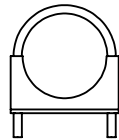

**SALES COPY**

**SAME AS P/N: 1001099051**

**CATALYTIC EXHAUST PRODUCTS LIMITED**

30 INTERMODEL DR. # 19-22, BRAMPTON, ON  
TEL:(905)-799-9770 FAX:(905)-799-9771

**SPECIFICATIONS:**

- MAKE:JLG
- MODEL:600A-100A
- ENGINE:DIESEL(TIER II) (65)HP
- FINISH:FLAT BLACK

**PROPRIETARY & CONFIDENTIAL**  
THE INFORMATION CONTAINED IN THIS DRAWING IS THE SOLE PROPERTY OF CATALYTIC EXHAUST PRODUCTS LTD. ANY REPRODUCTION IN PART OR AS A WHOLE WITHOUT WRITTEN PERMISSION IS PROHIBITED

TOLERANCES ARE AS FOLLOWS UNLESS NOTED OTHERWISE  
1 DEC PLACE ±.015  
2 DEC PLACES ±.010  
3 DEC PLACES ±.005

**6SXC-3220103**

DRAWN BY: **B** DWG. NO. SALES,6SXC-3220103 REV

ISSUED:18/03/2010 SCALE:N/A WEIGHT: SHEET 1 OF 1